

ACTION PAK® AP1690 MODEL



Benefits

- Field Configurable Input
Ranges for AC Voltage for Current
- Setpoint(s) Programmable
HI or LO
- Exclusive “Dynamic
Deadband” Prevents False
Trips
- Selectable Failsafe/
Latching Operation
- LED Trip Indicators
- Selectable 120/240VAC
Power
- Lifetime Warranty



AC Input, Field Configurable Limit Alarms

Provides Relay Contact
Closure(s) at a Preset AC-Input
Level

DESCRIPTION

The Action Pak model AP1690 dual setpoint limit alarm offers flexible, wide ranging AC input and relay output capability. Voltage spans from 100mV to 200VAC and current spans from 10mA to 100mAAC can be field configured. For current input spans of 1 to 5 Amps a 0.1Ω (0.1%) shunt resistor (Model #C006) is available. The AP1690 offers configurable latching, failsafe, and HI/LO operation. The unit also includes 0.25% to 50% adjustable deadbands and selectable 120/240VAC power (DC power optional).

DIAGNOSTIC LED

The Model AP1690 is equipped with a dual function diagnostic LED. The green center LED indicates line power and input signal status. Active line power is indicated by an illuminated LED. If the center LED is off, check line power and the wiring connection. If the input signal is above 100% full scale, the LED will flash at approximately 8Hz.

OUTPUT SELECTION

The dual setpoint AP1690 provides the following relay outputs:

AP1690 Single/Dual Trip
(2 SPDT, 5A)

Setpoints are top accessed multi-turn potentiometer(s) or option "P" provides top mounted ten-turn clock face dials.

OPERATION

The field configurable AP1690 limit alarm setpoints can be configured for HI, LO, latching and/or failsafe trip operation. Non-latching HI and LO setpoints have respective HI and LO deadbands. In a tripped condition, the setpoint is exceeded and the appropriate red LED will illuminate. The non-latching trip will reset only when the process falls below the HI deadband or rises above the low deadband (see figure 1). To reset a latched setpoint the signal must be in the safe region and the line power turned off for at least 5 seconds. For proper deadband operation, the HI setpoint must always be set above the LO setpoint.

In failsafe operation, the relay is energized when the process is below the HI setpoint or above the LO setpoint (opposite for non-failsafe). In the failsafe mode, the relays go to the trip condition when power fails.



*Protecting the
Integrity of
Industrial Process
Signals*



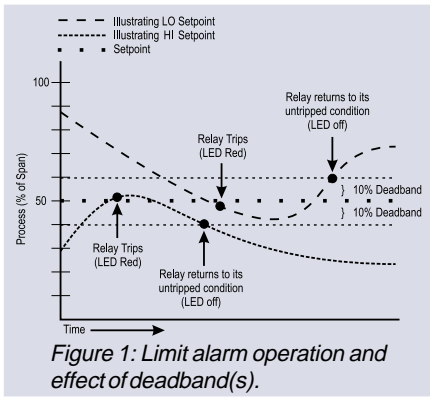

Figure 1: Limit alarm operation and effect of deadband(s).

DYNAMIC DEADBAND

The input must remain beyond the setpoint for 100 milliseconds, uninterrupted, to qualify as a valid trip condition. Likewise, the input must fall outside the deadband and remain there for 100 milliseconds to return the alarm to an untripped condition. This effectively results in a “dynamic deadband” — based on time — in addition to the normal deadband.

OPTIONS

- U** Urethane coating of internal circuitry for protection from corrosive atmospheres.
- P** Top Mounted, Ten-Turn Clockface Dial(s) for setpoint adjustment.
- C620** Factory calibration of input range, set points and output relays. Not available with option P.

CONFIGURATION

The factory presets are as follows:

Input 0-500mV
 Output Dual, SPDT
 Trip A: HI, B: LO
 Latching No
 Failsafe No
 Deadband A/B: 0.25%
 Power 120VAC

For other input ranges, remove the four base screws and case to access the configuration switches.

Replace the cover before applying power.

Refer to Figure 4 for switch locations.

INPUT

1. Position input jumper “W1” for voltage or current inputs.

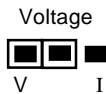

2. Using Table 1, position “W2” and set DIP switches “S1-S6” for the desired maximum setpoint input. Round desired maximum input values to the next highest range (e.g., 0-120V = 200V range).

OUTPUT

1. Configure the Mode Selector for the required function. See Figure 5.

POWER

1. Configure the AC jumpers for either 120 or 240VAC operation. See Figure 6.

CALIBRATION

Note: To maximize thermal stability, final calibration should be performed in the operating installation, allowing approximately 1-2 hours for warmup and thermal equilibrium of the system.

Setpoint: Set deadband at its minimum (factory default - fully CCW) before adjusting the setpoint. With the specified trip voltage or current input applied, adjust setpoint until the relay trips. For HI trip calibration, start below the desired trip.

Deadband: Set deadband to its minimum (factory default - fully CCW). Set setpoint to desired trip. Adjust voltage or current input until relay trips. Readjust deadband to 50% (fully CW). Set voltage or current input to desired deadband position. Slowly adjust deadband until relay untrips.

TYPICAL APPLICATION

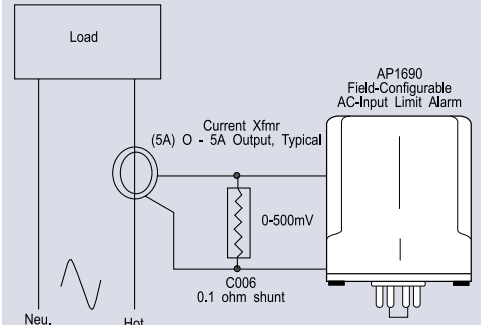

Load monitoring using a current transformer and the AP1690

FACTORY ASSISTANCE:

For additional information on calibration, operation and installation please contact Action’s Technical Services Group. Call toll-free:

800-767-5726

Table 1: AP1690 Input Range Selector-Switch Settings

Voltage	Current	Input Range Selector
100mV	10mA	SW1: ON, 1: up, 2: down, 3: down, 4: down, 5: down, 6: down; W2: L, H
200mV	20mA	SW1: ON, 1: up, 2: down, 3: down, 4: down, 5: down, 6: down; W2: L, H
500mV	50mA	SW1: ON, 1: up, 2: down, 3: down, 4: down, 5: down, 6: down; W2: L, H
1V	100mA	SW1: ON, 1: up, 2: down, 3: down, 4: down, 5: down, 6: down; W2: L, H
2V		SW1: ON, 1: up, 2: down, 3: down, 4: down, 5: down, 6: down; W2: L, H
5V		SW1: ON, 1: up, 2: down, 3: down, 4: down, 5: down, 6: down; W2: L, H
10V		SW1: ON, 1: up, 2: down, 3: down, 4: down, 5: down, 6: down; W2: L, H
20V		SW1: ON, 1: up, 2: down, 3: down, 4: down, 5: down, 6: down; W2: L, H
50V		SW1: ON, 1: up, 2: down, 3: down, 4: down, 5: down, 6: down; W2: L, H
100V		SW1: ON, 1: up, 2: down, 3: down, 4: down, 5: down, 6: down; W2: L, H
200V		SW1: ON, 1: up, 2: down, 3: down, 4: down, 5: down, 6: down; W2: L, H

Table 3: AP1690 Input Jumper Settings

Input	Input Jumper Selector (W1)
Voltage	V, I
Current	V, I

SPECIFICATIONS

Inputs	Voltage Input Range: 100mV to 200VAC Impedance: >100K Ω Overvoltage: 300VAC, max. Current Input Range: 10mA to 100mAAC Impedance: 20 Ω , typical Overcurrent: 200mAAC, 60V peak, max Frequency Range: DC to 400Hz, factory calibrated at 60Hz Common Mode (Input to Ground): 1000V, max	Stability	Line Voltage: $\pm 0.01\%$ %, max. Temperature: $\pm 0.025\%$ of full scale/ $^{\circ}\text{C}$, max.
LED Indications	Input Range (Green) >100% input: 8Hz flash (approx) Setpoint (Red): Tripped: Solid red Safe: Off	Common Mode Rejection	DC to 60Hz: 120dB
Limit Differentials (Deadbands)	0.25% to 50% of selected span	Isolation	1000VDC between contacts, input and power
Response Time	Dynamic Deadband: Relay status will change when proper setpoint/process condition exists uninterrupted for 100msec Normal Mode (analog filtering): <250msec, (10-90%)	ESD Susceptibility	Meets IEC 801-2, Level 2 (4KV)
Setpoint	Effectivity: Setpoint(s) are adjustable over 100% of the selected input span. Repeatability (constant temp): 0.1% of selected input span	Humidity	Operating: 15 to 95% (@45 $^{\circ}\text{C}$) Soak: 90% for 24 hours (@65 $^{\circ}\text{C}$)
		Temperature Range	Operating: 0 to 60 $^{\circ}\text{C}$ (32 to 140 $^{\circ}\text{F}$) Storage: -15 to 70 $^{\circ}\text{C}$ (5 to 158 $^{\circ}\text{F}$)
		Power	Consumption: 2W typical, 5W max Standard: Selectable 120/240VAC ($\pm 10\%$, 50-60Hz)
		Relay Contacts	1 SPDT (1 Form C) per setpoint Current Rating (resistive) 120VAC: 5A 240VAC: 2A 28VDC: 5A Material: Gold flash over silver alloy Electrical Life: 10 ⁶ operations at rated load <i>Note: External relay contact protection is required for use with inductive loads. See Relay Protection section.</i> Mechanical Life: 10 ⁷ operations
		Latch Reset Time	5 seconds
		Weight	0.64bs
		Agency Approvals	CSA certified per standard C22.2 (File No.LR42272-54). UL recog nized per standard UL 805 (File No. E99775)

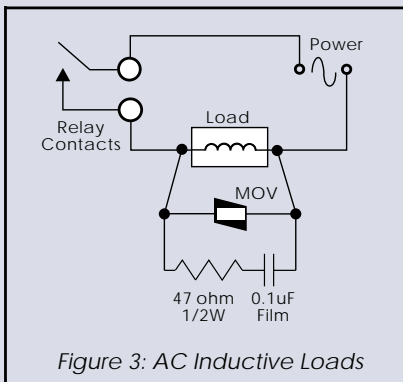
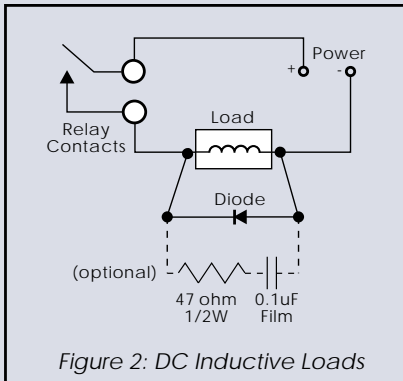

RELAY PROTECTION AND EMI SUPPRESSION

When switching inductive loads, maximum relay life and transient EMI suppression is achieved using external protection (see Figure 2 & 3). Place all protection devices directly across the load and minimize all lead lengths. For AC inductive loads, place a properly-rated MOV

across the load in parallel with a series RC snubber. Use a 0.01 to 0.1 μF pulse film capacitor (foil polypropylene recommended) of sufficient voltage, and a 47 Ω , 1/2W carbon resistor. For DC inductive loads, place a diode across the load (PRV > DC supply, 1N4006 recommended) with (+) to cathode and (-) to anode (the RC snubber is an optional enhancement).

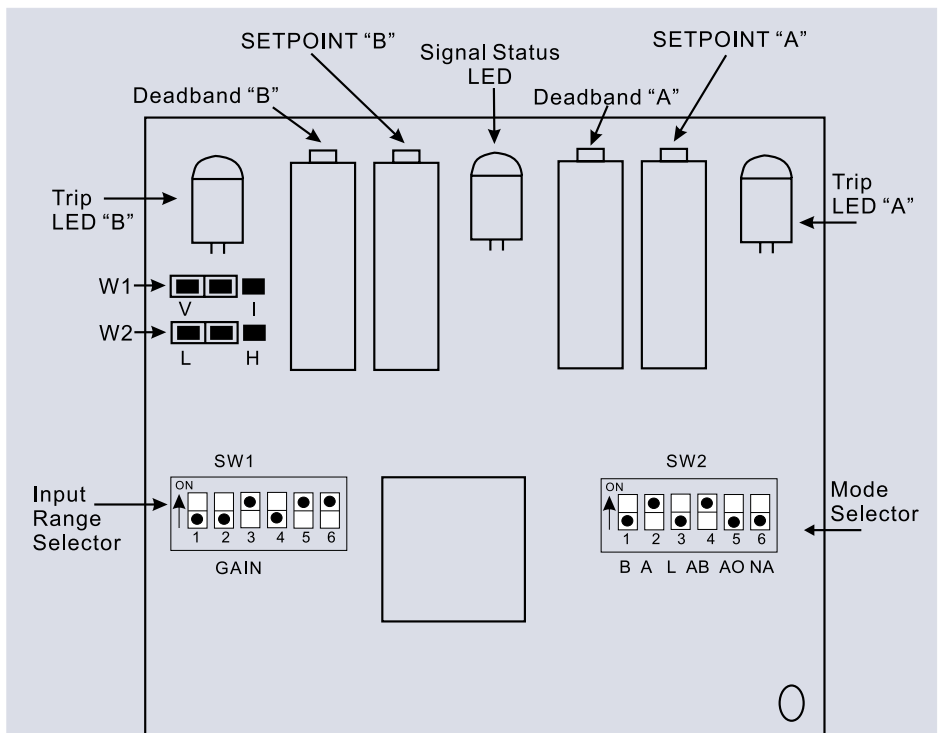

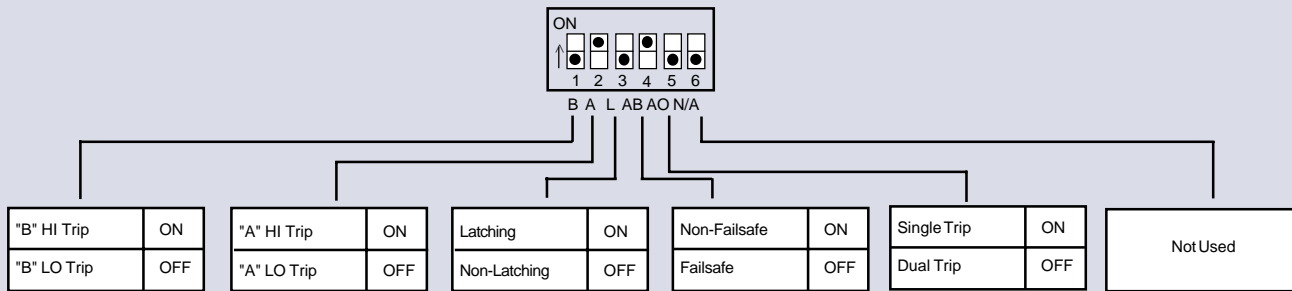
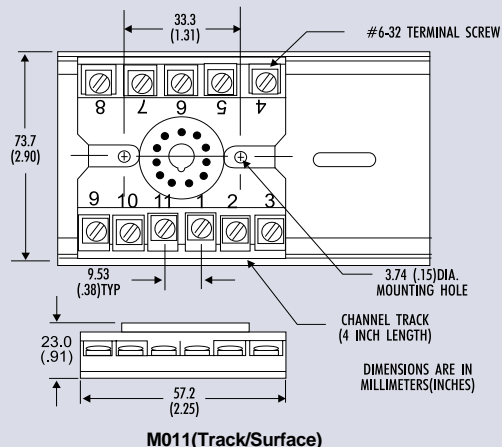
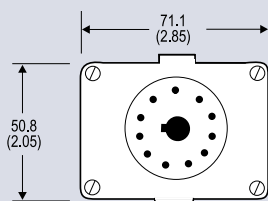
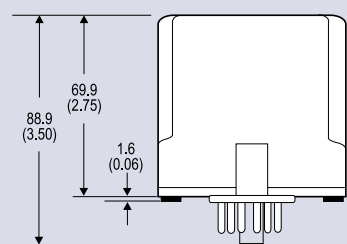

Figure 5: Mode Selection Dual Trip/A: HI, B: LO, Non-Latching, Non-Failsafe

DIMENSIONS

Dimensions are in millimeters (inches)



M011 (Track/Surface)

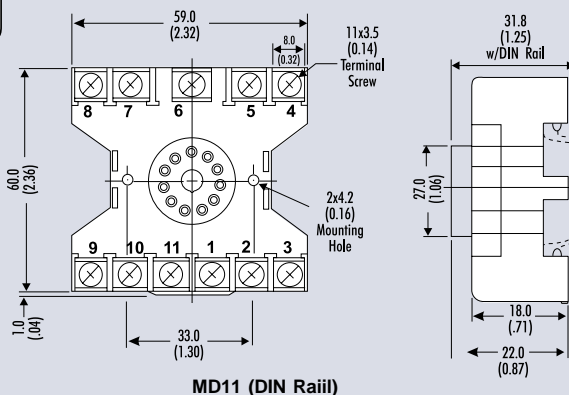

MD11 (DIN Rail)

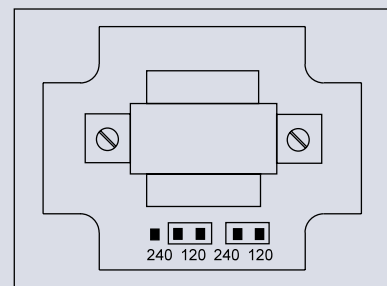

120 VAC Operation

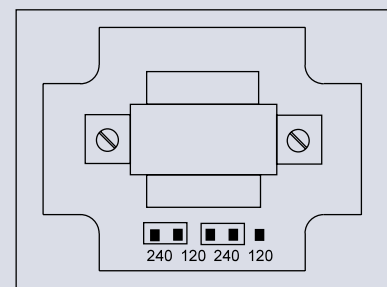

240 VAC Operation

Figure 6: 120/240 VAC Selection

MODELS & ACCESSORIES

Mounting

All Action Paks feature plug-in installation. Model AP1690 use an 11-pin base and either molded socket M011 or DIN rail socket MD11.

ORDERING INFORMATION

Specify:

1. Model: **AP1690-2000**
2. Options: U, P (see text)
3. Line Power (see specs.)
(All power supplies are transformer isolated from the internal circuitry)
4. **C006** (0.1Ω shunt for 1 to 5Amp current inputs).

Pin Connections

- 1 AC Power (Hot)
- 2 No Connection
- 3 AC Power (Neu)
- 4 Input
- 5 Input
- 6 N.O.
- 7 C
- 8 N.C.
- 9 N.O.
- 10 C
- 11 N.C.

Key:

N.O. = Normally Open
C = Common
N.C. = Normally Closed

*Contacts are in the "normal" state when the relay is de-energized.

大连爱克新仪器有限公司

地址:辽宁省大连市中山区七七街23号海鹰大厦403室 邮编:116001

电话:0411-82650498 82597851 传真:0411-82650478

网址:爱克新产品 <http://www.actionio.com.cn>

e-mail:sales@actionio.com.cn support@actionio.com.cn



网址:欧陆产品 <http://www.eurotherm.com.cn>

e-mail:sales@eurotherm.com.cn support@eurotherm.com.cn