



Copyright © April 1997 Barber-Colman Company

1260-IN-010-0-03

## The Impressor Hand-Held Portable Hardness Tester



*Instruction Manual*



A Siebe Group Product

# The Impressor

## Operation

The Impressor is intended for handheld testing of hardness for the following materials (aluminum and aluminum alloy, soft metals, plastics, fiberglass, rubber and leather). Harder materials cannot be tested with the Impressor. For information on the available impressor models, refer to the current revision of the Barber-Colman Product Guide.

To test a surface, place the indenter point and the leg of the impressor on the same plane of the surface. Make certain that no indentations from previous use are within 1/16th of an inch of the present indenter point position, to insure reading accuracy. Readings should not be taken on both sides of the .031-thick test disks. Readings taken on top of old indentations will adversely affect the accuracy of the reading. An ample supply of appropriate test discs should be maintained for these reasons.

Press down firmly, but carefully, on the impressor handle. Observe the indicator reading, noting the peak reading. For softer materials there will be some falling-off of the reading from the peak value. This is normal and is due to the nature of the materials being tested.

As a general rule, the number of readings taken increases with the softness of the materials being tested. Refer to the table below for recommended minimal numbers of readings for various materials using the Model GYZJ 934-1. Though specific numbers for Models GYZJ 935 and GYZJ 936 are not included due to correlation difficulties with softer materials, the numbers suggested for reinforced plastics serve as a starting point for softer materials.

### Recommended Numbers of Reading for Model 934-1

	<b>GYZJ 934-1 Reading Range</b>	<b>For an Average Variance of</b>	<b>Recommended Number of Readings</b>
<b>Homogeneous Material:</b>	80	0.28	3
	70	0.28	4
	60	0.28	5
	50	0.28	6
	40	0.28	7
	30	0.28	8
	20	0.28	9
<b>Reinforced Plastics:</b>	70	0.72	5
	60	0.78	10
	50	0.75	16
	40	0.78	22
	30	0.77	29

# The Impressor

## Operation (continued)

The indenter point must always be perpendicular to the surface being tested. To maintain perpendicularity, the leg of the Impressor must be on the same plane as the indenter point, with both flats of the leg touching the same surface. Irregularly-shaped objects to be tested should be mounted in a holding jig to assure that perpendicularity is maintained. For flat objects, a temporary offset of the leg to accommodate the thickness of the part being tested can be obtained by placement of washer(s) of appropriate thickness between the leg and the case of the impressor. Without perpendicularity, accuracy of the reading cannot be assured.

## Maintenance

The Impressor is a precision mechanical instrument and should always be handled with care. The deflection indicator built-in to the Impressor has a normal reading of zero when not in use.

The Indenter Point has a tip precisely-machined to very small dimensions and should be used with care to prevent damaging it. Avoid sliding or scraping the Indenter Point when it is in contact with the surface being tested. If the Indenter Point becomes damaged, it must be replaced with a new one. The Impressor ships with two spare Indenter Points.

### **WARNING**

Do not attempt to regrind an Indenter Point when damaged! The mechanical dimensions of the Indenter Point determine the accuracy of readings and will create erroneous reading when reground.

To check the condition of the indenter point, first visually inspect it for damage. Then place the impressor on a hard, flat surface with the appropriate test disc positioned under the indenter point. Press the impressor handle down firmly, but carefully, to avoid sideways slippage of the indenter point. The reading on the indicator should be within the range of values stamped on the test disc. If it is not, refer to the calibration procedure below.

## Replacing the Indenter Point

1. Remove the two screws that hold the impressor case halves together (see Figure 1).
2. Lift out the frame while holding the spring sleeve in place (so it will not fall off) until it can be removed.
3. Loosen the plunger upper guide nut with the provided wrench until the cross-notched top lip protrudes above the frame.
4. Hold the impressor upside down (so the spring and plunger won't fall out), then loosen the lock nut with the provided wrench and remove the lower plunger guide.
5. Replace the indenter point in the lower plunger guide, then re-install the lower plunger guide, leaving about 3/16 of an inch of thread protruding below the frame.
6. Gently press the indenter point against a hard surface such as glass until the indicator shows a maximum reading. Care should be taken not to damage the indicator by forcing it beyond its full deflection of about 110 Barcol units on the dial. Tighten or loosen the lower plunger guide until a reading of 100 is obtained.

# *The Impressor*

## **Maintenance (continued)**

---

7. Tighten the lock nut, then re-check the maximum deflection as in step 6 above.
8. Tighten the plunger upper guide nut until its top is flush with the frame.
9. Calibrate the impressor per the procedure below.
10. Replace the spring sleeve, reassemble the case halves and screws, and test for the appropriate reading on the test discs.

## **Calibration Procedure**

---

Test the hardness of the appropriate test disc specified below. If the reading is higher than the larger value stamped on the test disc, tighten the plunger upper guide nut further into the frame. Test again. If the reading is lower than the smaller value stamped on the test disc, loosen the plunger upper guide nut. Test again. If reading within the specified limits cannot be obtained by plunger upper guide nut adjustment only, loosen the lock nut and make minor adjustments to the lower plunger guide. Retighten the lock nut and test again. Repeat until readings are between the values stamped on both test discs.

## **Test Discs for the Model 934-1**

---

Use the GYZJ 250 test disc stamped 87/89 for the model GYZJ 934-1 in step 9 above. Then repeat the procedure in step 9 using the GYZJ 78 test disc labelled 43-48. Iterate between these test discs until the optimum reading for both discs is obtained. This procedure will provide the optimum accuracy over the entire range of the 934-1. If optimized readings cannot be obtained on both test discs, this indicates that the indenter point may be damaged. Replacement of the indenter point is recommended.

The above procedure can also be used between any two reference materials with known Barcol values at the extremes of a portion of the impressor reading range. Calibration at these known values will provide enhanced accuracy within that portion of the range, but not outside of that range.

## **Test Disc for the Model 935**

---

Use the GYZJ 69 test disc stamped 87-89 for the Model GYZJ 935 in step 9 above.

## **Test Disc for the Model 936**

---

Use the GYZJ 70 test disc stamped 48-50 for the model GYZJ 936 in step 9 above.

# The Impressor

## Specifications

**Note:** Physical characteristics of very soft materials are such that uniform correlation between different hardness measuring systems cannot be established. For this reason, conversion curves should be considered tentative. We recommend that impressor hardness limits for each material be established by test.

### Typical Readings of Aluminum Alloys

Alloy and Temper:	1100-0	3003-0	3003H14	2024-0	5052-0	5052H14	6061T6	2024T3
GYZJ 934-1 reading:	35	42	56	60	62	75	80	85

### Approximate Conversion Curves for GYZJ 934-1

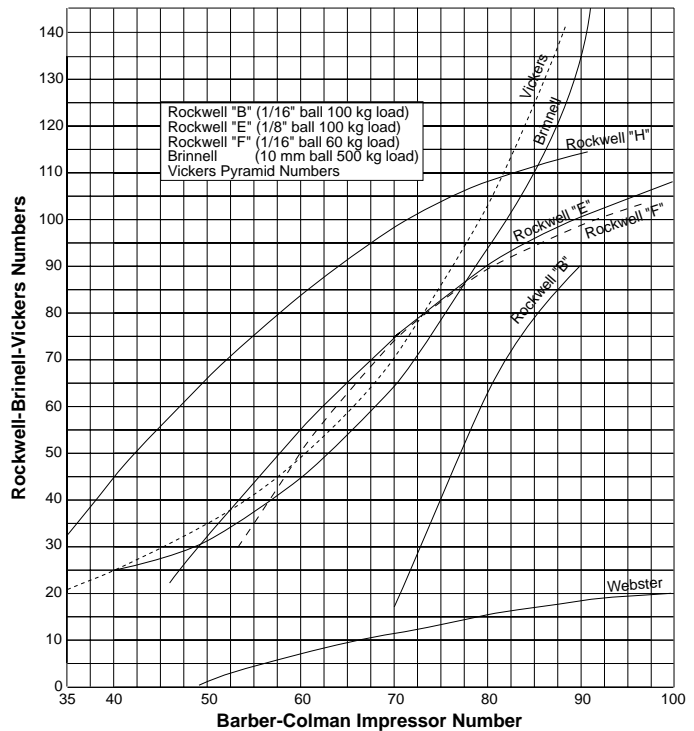

### Approximate Conversion Curves for GYZJ 935 & GYZJ 936

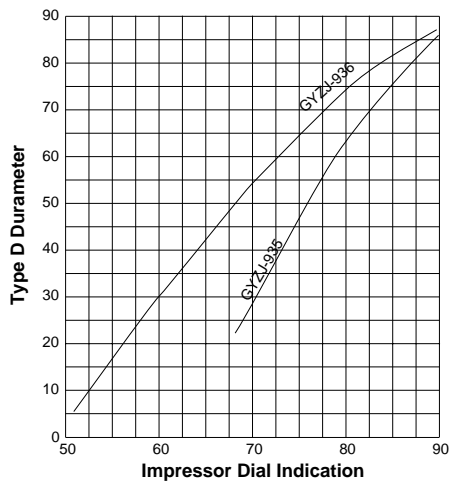

# The Impressor

## Operating Information (continued)

### Approximate Conversion Chart for GYZJ 934-1

GYZJ-934-1	Brinell 10mm 500kg	Vickers 5kg	Webster Model B	Rockwell			
				B	E	F	H
35		21					32
36		22					35
37		23					37
38		24					40
39		25					42
40	25	26					45
41	25	27					47
42	26	28					49
43	27	29					51
44	27	30					54
45	28	30					56
46	29	31					58
47	30	32			23		60
48	30	33	0.7		26		62
49	31	34	1.3		28		64
50	32	35	1.9		31		66
51	33	36	2.5		34		68
52	34	38	3.1		36		70
53	35	39	3.6		39	30	72
54	37	40	4.2		41	34	73
55	38	41	4.7		44	37	75
56	39	43	5.3		46	40	77
57	40	44	5.8		48	43	78
58	42	45	6.3		50	46	80
59	43	47	6.8		53	48	82
60	45	49	7.3		55	51	83
61	46	50	7.8		57	54	85
62	48	52	8.3		59	56	86
63	50	54	8.8		61	59	88
64	51	56	9.2		63	61	89
65	53	58	9.7		65	63	90
66	55	60	10.1		67	66	92
67	57	62	10.6		69	68	93
68	60	65	11.0		71	70	94
69	62	67	11.4		73	72	95
70	64	70	11.8	17	75	74	97
71	67	72	12.2	23	76	75	98
72	69	75	12.6	28	78	77	99
73	72	78	12.9	33	80	79	100
74	75	81	13.3	38	81	80	101
75	78	85	13.7	42	83	82	102
76	80	88	14.0	47	84	83	103
77	84	92	14.3	51	86	85	104
78	87	95	14.7	55	87	86	105
79	90	99	15.0	59	89	88	106
80	94	103	15.3	63	90	89	106
81	97	108	15.6	66	91	90	107
82	101	112	15.9	70	92	91	108
83	105	117	16.2	73	94	92	109
84	109	121	16.4	76	95	93	109
85	113	126	16.7	79	96	94	110
86	117	131	16.9	81	97	95	111
87	121	137	17.2	84	98	96	111
88	126	142	17.4	86	99	97	112
89	130		17.6	88	100	98	112
90	135		17.8	90	101	98	113
91	140		18.0		102	99	114
92	145		18.2		103	100	
93			18.4		103	100	
94			18.6		104	101	
95			18.7		105	102	
96			18.9		106	102	
97			19.0		106	103	
98			19.2		107		
99			19.3		107		
100			19.4		108		

### Approximate Conversion Chart for GYZJ-935 and GYZJ-936

Type D Durameter	GYZJ-935	GYZJ-936
52		6
53		9
54		12
55		15
56		18
57		21
58		24
59		27
60		30
61		32
62		35
63		38
64		40
65		43
66		45
67		48
68	22	50
69	26	52
70	30	54
71	34	57
72	38	59
73	41	61
74	45	63
75	48	65
76	51	67
77	54	69
78	57	70
79	60	72
80	63	74
81	66	76
82	69	77
83	71	79
84	74	80
85	76	82
86	79	83
87	81	85
88	83	86
89	85	87
90	87	88

# The Impressor

## Repair Parts

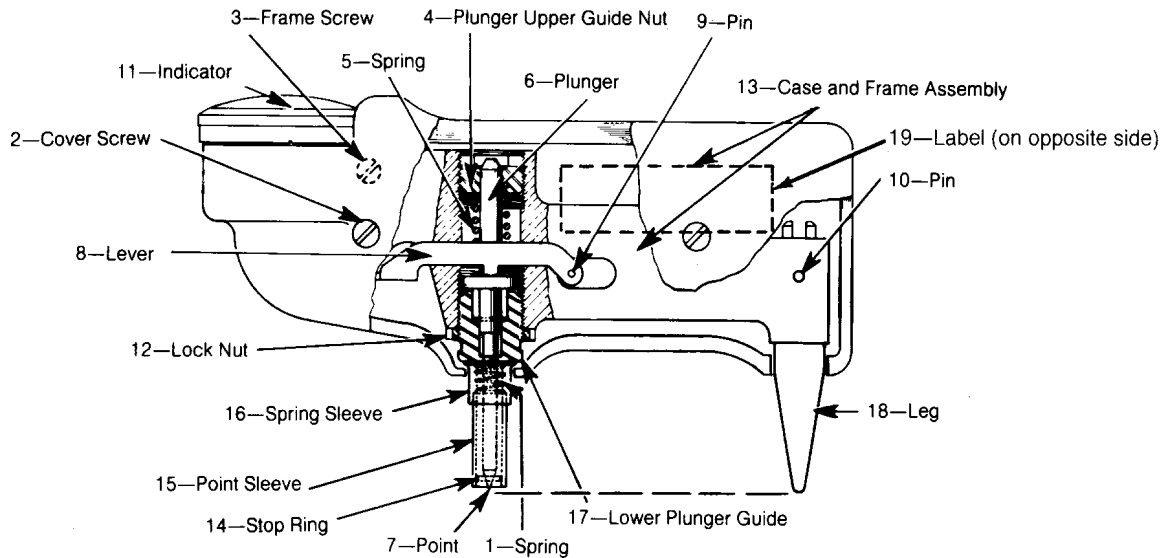

Figure 1. Impressor Cutaway

Contact factory (RPPL) for repair parts prices

Item	GYZJ-934-1	GYZJ-935	GYZJ-936	Description	Qty
1	AYRS-62	AYRS-62	AYRS-62	Spring	1
2	BYRF-3114	BYRF-3114	BYRF-3114	Cover Screw	2
3	BYRF-250	BYRF-250	BYRF-250	Frame Screw	1
4	GYZJ-2	GYZJ-2	GYZJ-2	Plunger Upper Guide Nut	1
5	GYZJ-3	AYRS-146-1	AYRS-146-1	Spring†	1
6	GYZJ-4-1	GYZJ-4-1	GYZJ-4-1	Plunger	1
7	GYZJ-6-5	GYZJ-6-5	GYZJ-67	Indenter Point†	1
8	GYZJ-7	GYZJ-7	GYZJ-7	Lever	1
9	GYZJ-8	GYZJ-8	GYZJ-8	Pin	1
10	DYRA-218	DYRA-218	DYRA-218	Pin	1
11	GYZJ-15-2	GYZJ-15-2	GYZJ-15-2	Indicator (not field servicable)	1
12	GYZJ-16	GYZJ-16	GYZJ-16	Lock Nut	1
-	GYZJ-17-1	GYZJ-17-1	GYZJ-17-1	Wrench	1
-	GYZJ-19-2	GYZJ-19-2	GYZJ-19-2	Carrying Case	1
13	GYZJ-23-1	GYZJ-23-1	GYZJ-23-1	Case & Frame Assembly	1
14	GYZJ-61	GYZJ-61	GYZJ-61	Stop Ring	1
15	GYZJ-62	GYZJ-62	GYZJ-62	Point Sleeve	1
16	GYZJ-63	GYZJ-63	GYZJ-63	Spring Sleeve	1
17	GYZJ-64	GYZJ-64	GYZJ-71	Lower Plunger Guide†	1
18	GYZJ-65	GYZJ-65	GYZJ-65	Leg	1
19	GYZJ-79-1	GYZJ-79-2	GYZJ-79-3	Label†	1

† Parts required to convert between models.

## Hardness Tester

Model	Range
GYZJ-934-1	25 to 50 Brinell (10 mm ball 500 kg load)
GYZJ-935	For softer plastic and very soft metals
GYZJ-936	For extremely soft material

# The Impressor

## Certified Test Disks

<u>Part No.</u>		<u>Use with Model</u>	<u>Barber-Colman Scale</u>
GYZJ-069-100	Set of 5	GYZJ-935	87 – 89
GYZJ-070-100	Set of 5	GYZJ-936	48 – 50
GYZJ-078-100	Set of 5	GYZJ-934-1	43 – 48
GYZJ-250-100	Set of 5	GYZJ-934-1	87/89

## Standard Test Disks

GYZJ-069	Each	GYZJ-935	87 – 89
GYZJ-070	Each	GYZJ-936	48 – 50
GYZJ-078	Each	GYZJ-934-1	43 – 48
GYZJ-250	Each	GYZJ-934-1	87/89



**Barber-Colman Company**  
Industrial Instruments Division  
1354 Clifford Avenue  
P.O. Box 2940  
Loves Park, IL U.S.A. 61132-2940

Telephone +1 800 232 4343  
Facsimile +1 815 637 5341  
<http://www.barber-colman.com>

**大连爱克新仪器有限公司**

[www.actionio.com.cn](http://www.actionio.com.cn)

辽宁省大连市中山区七七街23号海鹰大厦403室

电话:0411-82650498 传真: 0411-82650478

Email: [Sales@actionio.com.cn](mailto:Sales@actionio.com.cn) [Support@actionio.com.cn](mailto:Support@actionio.com.cn)