

TRANSPAK™ T713 MODEL



Benefits

- Eliminates Ground Loops with 600V Input-to-Output Isolation
- Easy Field Configurable, Switch Selectable Input Ranges
- Wide Ranging Zero and Span Adjustability (80%)
- Integral RTD Linearization/Output Linear to Temperature
- FM Safety Approval for Hazardous Installations
- Three Year Warranty



RTD Input Isolating, Field Configurable Two-Wire Transmitter

Provides an Isolated, Linearized Current Loop in Proportion to a 3-Wire RTD Input (100Ω Pt)

DESCRIPTION

The T713 series offers the user the choice of 6 widely adjustable input ranges and 2 output ranges, which are field selectable via top accessed DIP switches (see Tables 1 and 2). The T713 provides 600VDC of isolation with outputs of either 4-20mA or 10-50mA. Current outputs are linear to temperature.

A major advantage of the T700 Series is their truly wide ranging capability. The T713 enables 80% zero and span adjustability within any user selected input range. For example, Range 1 of Table 1 specifies 0 to 1000° F with a minimum span of 200° F (1000° - 200° = 800°, or 80%). This 80% adjustability factor allows the user to field calibrate the unit for the maximum (0 to 1000°) down to any minimum (200°) span (e.g. 740° to 940°) — as long as that adjusted span remains within the selected 0 to 1000°F range. The same is true for any adjustable span, minimum or otherwise, in any user selectable range. All spans are field adjustable from 20% (minimum span) to 100% of the specified range.

Urethane coating of internal circuitry for protection from corrosive atmospheres is included, standard.

APPLICATION

Model T713 is useful in any application requiring an isolated two wire loop current from a 3-wire RTD. Typical applications include SCADA and remote data acquisition such as monitoring boiler or custody transfer/pipeline temperatures. The output of the T713 can be used to drive a digital meter for direct display or interface with a computer for monitoring and control applications.



*Protecting the
Integrity of
Industrial
Process Signals*



The model T713 is FM approved for intrinsically safe operation in Class I, Division 1, Groups A, B, C, and D; Nonincendive Class I Division 2, Groups A, B, C and D, and Classes II & III, Division 2, Group G hazardous locations when installed per manufacturer's drawing 790-0024-00. Refer to model F713 for NEMA 4, FM/CSA/CENELEC approved explosion proof housing.

CALIBRATION

Note: Factory settings are: Input Range 1; 4-20mA output.

1. Open the access lid on the top of the unit (see Top View Diagrams).
2. Select the output range using switch S4. The CLOSED position selects a 10-50mA output. The OPEN position selects a 4-20mA output.
3. Select input range from Table 1 or 2 and configure switches S1 through S3.
4. Connect the input to a calibrated 3-wire resistance source and monitor output current (refer to terminal wiring).
5. Set the calibrator to desired minimum temperature.
6. Adjust the coarse zero rotary switch to obtain an output of approximately 4mA or 10mA. Adjust the fine zero for exact calibration.

Table 1: T713-0000 Input Ranges

Input Range (100Ω Pt RTD) 0.00385 alpha	°F		°C		To Select Range Position Switch		
	Input Limits	Minimum Span	Input Limits	Minimum Span	S1	S2	S3
1	0 to 1000	200	0 to 600	120	OPEN	OPEN	CLOSED
2	0 to 500	100	0 to 300	60	OPEN	CLOSED	OPEN
3	30 to 130	40	0 to 50	10	CLOSED	OPEN	OPEN

Table 2: T713-0013 Input Ranges

Input Range (100Ω Pt RTD) 0.00385 alpha	°F		°C		To Select Range Position Switch		
	Input Limits	Minimum Span	Input Limits	Minimum Span	S1	S2	S3
1	-300 to 700	200	-200 to 360	120	OPEN	OPEN	CLOSED
2	-300 to 200	100	-200 to 85	60	OPEN	CLOSED	OPEN
3	-300 to -250	40	-200 to -155	20	CLOSED	OPEN	OPEN

tion. Note that it may become necessary to switch coarse zero up or down one position.

7. Set the calibrator to the desired maximum temperature and perform similar adjustments using the coarse span switch and fine span potentiometer.

TERMINAL CONNECTIONS

T713

- 1 Loop Output (-)
- 2 Loop Output (+)
- 3 RTD Exc (+)
- 4 RTD (+)
- 5 RTD (-)
- 6 Shield (Gnd)

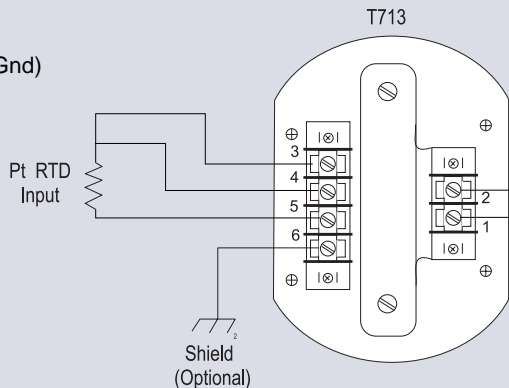

WIRING EXAMPLE

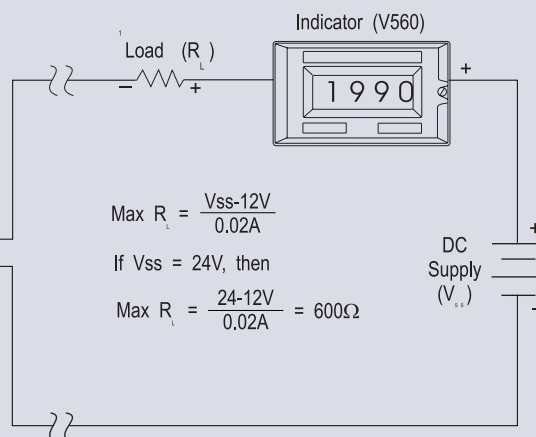

¹ NOTE: R_L represents any other device loads in the current loop.

² NOTE: For best RF and common mode rejection, ground case (pin #6)

SPECIFICATIONS

Input Span Range (Max/Min)	See Tables 1,2
Excitation Current	1mA, typical
Leadwire Resistance Effect	1% of span error with up to 40Ω/lead
Output Span	4-20mA/10-50mA, switch selectable
Minimum Output Current	3.3mA, typical
Maximum Output Current	4-20mA: 24mA, typical 10-50mA: 58mA, typical
Supply Voltage Range	4-20mA: 12 to 80VDC 10-50mA: 12 to 60VDC
Maximum Change in Supply-Voltage Effect	0.05% of span
Maximum Change in Load Effect	0.05% of span
Loop Voltage Drop	12VDC @ 20mA
Linearizing Accuracy	T713-0000: ± 0.1% of standard R/T tables, typical; 0.2% max. T713-0013: ± 0.21% of standard R/T tables, typical; 0.3% max.

Stability	Zero: ± 0.02% of span/°C, typical, or 2mV, whichever is greater Span: ± 0.01% of span/°C, typical
Overall Accuracy (Includes Linearity, Hysteresis, Stability)	± 0.5% of any adjusted span, max.
Zero and Span Adjustability	80% of any selected range
Repeatability	± 0.05% of span, typical
Response Time	150ms, typical, 400ms max.
Output Ripple	0.1% of span, rms, typical
RFI Effect (5W, 470MHz at 3 Ft.)	<1% of span error
Isolation	600V DC maximum, input to output to case
Temperature Range	Operating: -40 to 80°C (-40 to 176°F)
Weight	0.64lbs
Agency Approval	FM approved intrinsically safe for hazardous locations, certificate No. J.I. 2M2A5.AX (3611).

TOP VIEW DIAGRAM

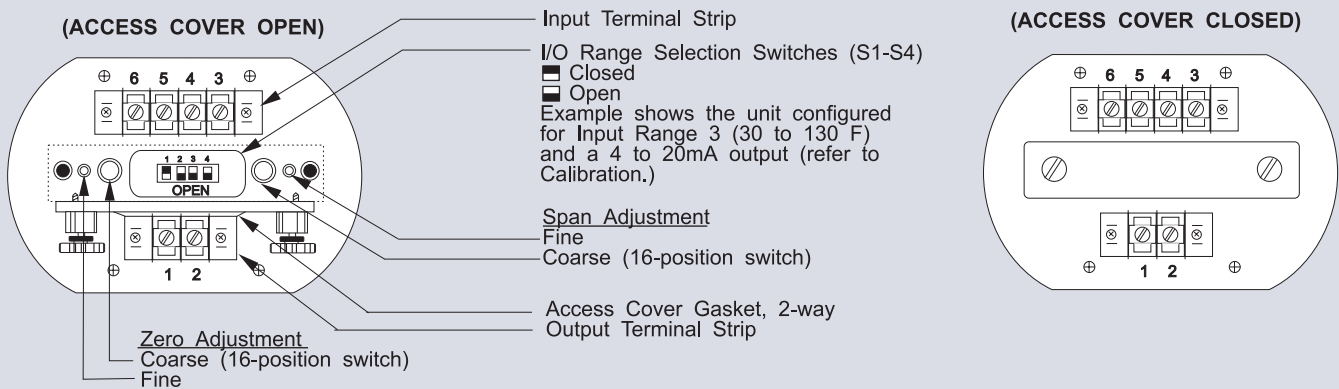

MOUNTING HARDWARE

All dimensions are shown in millimeters (Inches)

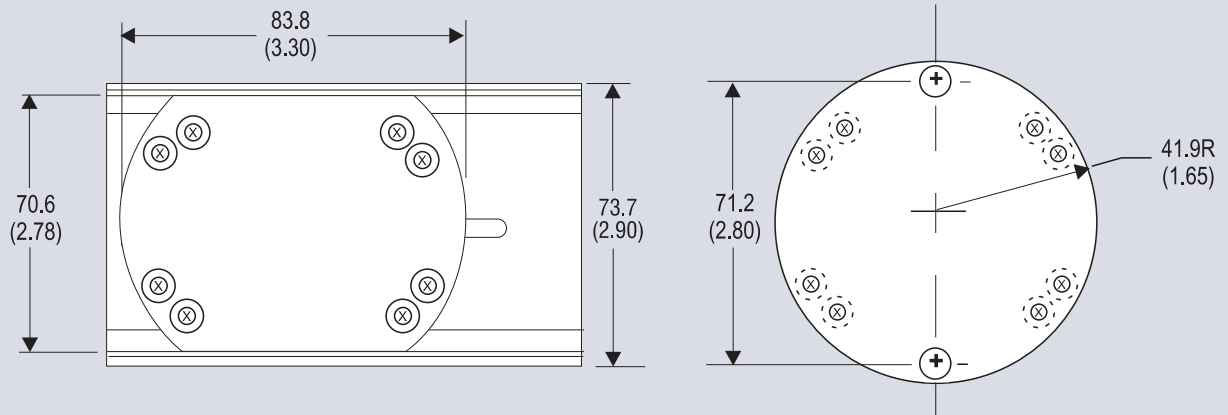

T902 MOUNTING PLATE
 (For snap-track mounting;
 includes snap track)
 Aluminum Alloy #6061 (0.06in, thick)

T910 MOUNTING PLATE
 (For bulkhead mounting)
 Aluminum Alloy #6061 (0.06in, thick)

T804 CONDUIT DEVICE HOUSING

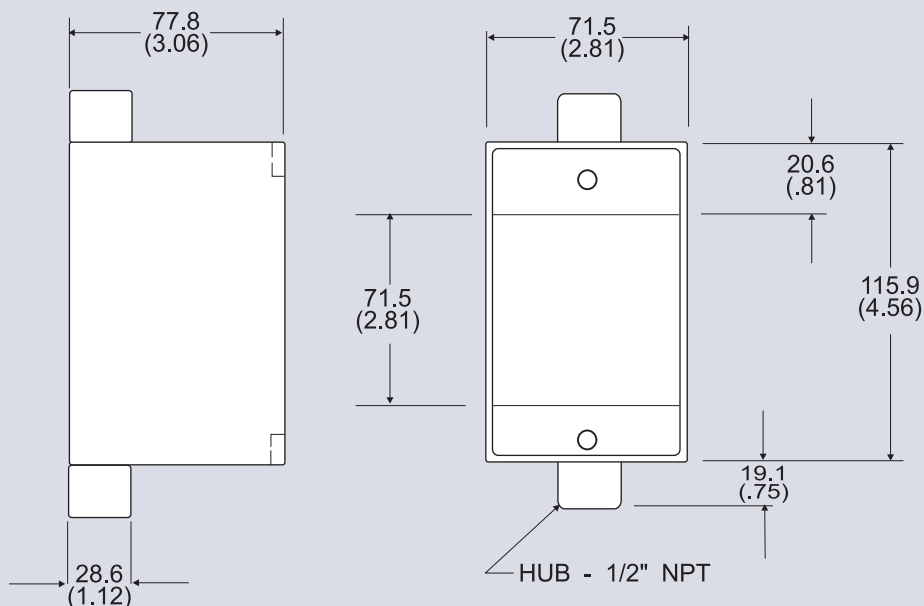

DIMENSIONS

All dimensions are shown in millimeters (Inches)

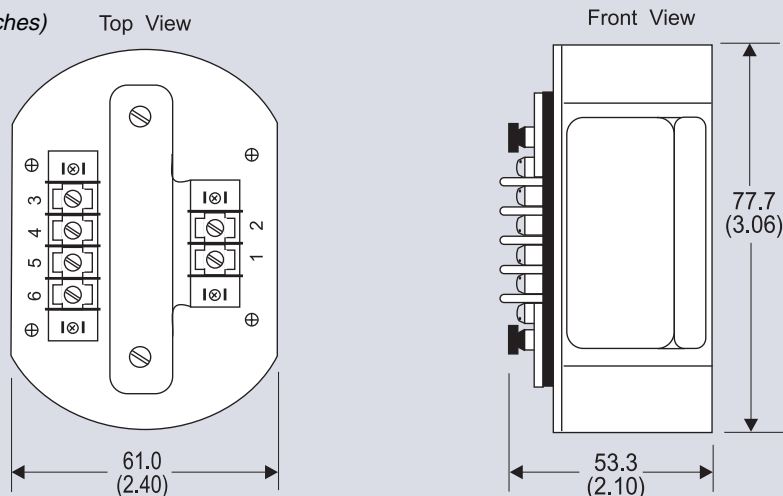

FIELD MOUNTING

The T713 is designed for installation in industrial field environments. A sealed, die-cast aluminum housing protects against corrosion, moisture, dust and electrical noise such as radio-frequency (RFI) and electromagnetic (EMI) interference. All circuit boards are urethane coated for environmental protection and FM approval.

For protection against extreme moisture, hose directed water (NEMA 4) or hazardous environments, use Action's FieldPak model F713. The F713 2-wire transmitter offers the same wide ranging features of the TransPak T713, but includes a rugged EP/NEMA 4 enclosure with standard, ready to install plumbing ports for easy hookup and operation in harsh process environments.

MODELS & ACCESSORIES

Accessories

Model Description

- M004** Snap-in Channel Track, 4 feet (nonconducting).
- T902** Mounting plate for M004, includes 4" track.
- T910** Bulkhead (flat surface) mounting plate.
- T804** Conduit device housing.
- 9046** Action Pak 24/40VDC, 65mA Power Supply.
- T609** 24V, 600mA Loop power Supply.
- V565** 3-1/2 digit remote loop-powered indicator, wide ranging display, NEMA 4X enclosure, CSA & FM approval standard. Specify Option C to house Transpak.
- C620** Factory calibration (user specified)

Ordering Information

Specify:

1. Model: **T713-0000**
T713-0013 (-200°C offset)
2. Optional Custom Factory Calibration:
Specify **C620** with desired input and output range.

大连爱克新仪器有限公司

地址:辽宁省大连市中山区七七街23号403室

电话: 0411-82650498 82597851 13909856458

传真: 0411-82650478 邮编: 116001

E-mail: sales@actionio.com.cn xctlcy@mail.dlptt.ln.cn
support@actionio.com.cn

www.actionio.com.cn



DALIAN ACTION INSTRUMENTS