

WV108

MODEL

- Adjustable Setpoints
Programmable HI or LO
Failsafe or Non-failsafe
- Greatly Improved Input/
Output Accuracy and
Stability
- Configurable with or
without Ethernet Connec-
tion
- Direct Access to Sensor
Data when Connected to
the Intranet (with optional
WVC16)
- Provides Remote Diagnos-
tic Capability (with
optional WVC16)
- Versatile Alarm Capabilities
Provide Email Notification
when Problems Occur
(with optional WVC16)
- Lifetime Warranty



WV Series DC Input, Limit Alarm

Provides Relay Contact Closure(s) at a Preset DC Input Level

DESCRIPTION

The WV Series from Eurotherm Action Instruments is an exciting new line of isolating signal conditioners. This new line provides features never before found in traditional signal conditioners. The WV Series has greater input and output accuracy than most signal conditioners on the market today. In addition, the stability of the unit beats that of most signal conditioners as well. The WV Series also provides the user with the capability to view sensor data directly over your company's intranet with a standard web browser. Just imagine, the WV Series will allow you to view configuration, maintenance and process information through a remote web browser. Further, the modules are capable of generating e-mail messages, triggered when process variables or maintenance based performance parameters exceed or fall below pre-set levels.

The WV108 is a DC Voltage or Current Input Limit Alarm with dual setpoints and two contact closure outputs. The field configurable input and alarm functions offer flexible setpoint capability. Five input voltage ranges are available between $\pm 20\text{mV}$ and $\pm 200\text{V}$. There are two current input ranges, $\pm 10\text{mA}$ and $\pm 100\text{mA}$. All ranges allow the setpoints to be fully adjustable throughout the whole range.

There are two versions of the WV108, the WV108-0000 and the WV108-0001. The WV108-0000 contains standard SPDT relays. When power is removed, the relays revert to their non-powered state. The WV108-0001 contains latching relays. Whatever position they are in when power is removed is where they will remain when power is re-applied. A reset switch is provided to reset the relays after the alarm is no longer true. Both models are configurable as a single or dual setpoint alarm, with HI or LO trips. The WV108-0000 supports failsafe or non-failsafe operation.



ACTION INSTRUMENTS

OPERATION

The field configurable WV108 limit alarm setpoints can be configured for HI or LO, failsafe or non-failsafe operation (failsafe only available on the -0000). Each of the setpoints has a respective HI or LO deadband. In a tripped condition, the setpoint is exceeded and the appropriate red LED will illuminate. The trip will reset only when the process falls below the HI deadband or rises above the LO deadband. (The WV108-0001 requires pressing the reset switch in order to reset the relay after being tripped.) The deadband can be left at the minimum level (the factory default) or can be set to whatever level is desired. In failsafe operation (-0000 only), the relay is energized when the process is below the HI setpoint or above the LO setpoint (opposite for non-failsafe). In the failsafe mode, a power failure results in an alarm state output.

ENHANCED LED DIAGNOSTICS

Other than when executing the push button calibration routine, the LEDs blink under the following conditions:

RUN (Green):

On when unit is powered
Flashes at 2Hz when input under range.
Flashes at 8Hz when input over range.

SETPOINT A (Red):

On when Setpoint A is tripped.
Status for setting Setpoint A
Flashes while calibrating the input level

SETPOINT B (Red):

On when Setpoint B is tripped
Status for setting Setpoint B
On while calibrating the input level

An Under range condition exists when the signal is lower than the operational low value minus 6.25% of the operational span. An Over Range condition exists when the signal is higher than the operational high value plus 6.25% of the operational span.

DIMENSIONS

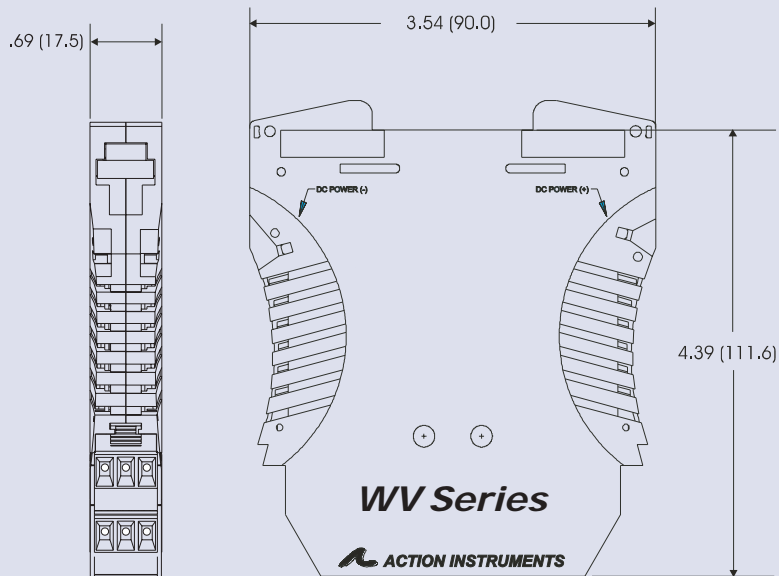

CONFIGURING MODULES

Configuration is accomplished via setting DIP switches and using a push button for adjusting the setpoints. Additionally, it is possible to remotely select the setpoints using an Ethernet connection and the optional WVC16 WebView Communications Interface module. Browsers supported include Internet Explorer 5 or later and Netscape Navigator 4.7. With the addition of the Ethernet interface, the user has the ability to have setpoint trip conditions generate an e-mail message for up to 10 recipients. The module also contains a countdown timer that can be used to notify when routine maintenance is required, such as re-calibration. The internal temperature of the module can also be monitored via the Ethernet connection.

WV SERIES COMMUNICATIONS INTERFACE (OPTIONAL)

Each WVC16 is capable of communicating with up to 32 I/O modules. The interface contains a web page server and an e-mail server as well as being the interface to the modules. All memory to support the signal conditioner's historical data, storage of the web pages and all e-mail messages is contained in the WVC16.

The WVC16 actually downloads a JAVA applet to the client's computer. The applet provides access to the signal conditioner's data. The information available includes the following:

- Module configuration summary
- Module configuration editing
- Diagnostic/warning status
- Alarm setup & status
- E-mail setup, editing & address book
- Process variable viewing

WIRING CONNECTIONS

Pin	Description
11	N.O. Relay B
12	Com. Relay B
13	N.C. Relay B
21	DC Power (+)
22	DC Power (-)
23	No Connection
41	Analog Input (+)
42	Analog Input (-)
43	24VDC Excitation (+)
51	N.O. Relay A
52	Com. Relay A
53	N.C. Relay A

TERMINAL DESIGNATIONS

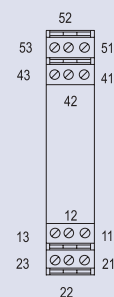

FACTORY ASSISTANCE

For additional information on installation, operation and calibration, please contact Eurotherm's Technical Services Group. Call toll free:

86-411-82650498

SPECIFICATIONS

Electrical

Inputs	Voltage Input Ranges: $\pm 20\text{mV}$, $\pm 200\text{mV}$, $\pm 2\text{V}$, $\pm 20\text{V}$ & $\pm 200\text{V}$ Impedance: $> 100\text{k}\ \Omega$ Overvoltage: 200Vrms, max. Current Input Range: $\pm 10\text{mA}$ & $\pm 100\text{mA}$ Impedance: $20\ \Omega$, typical Overcurrent: 170mA rms, max Overvoltage: 60VDC	
Minimum Deadband	<u>Range</u>	<u>Deadband</u>
	$\pm 20\text{mV}$	0.2% (80 μV)
	$\pm 200\text{mV}$	0.2% (800 μV)
	$\pm 2\text{V}$	0.1% (4mV)
	$\pm 20\text{V}$	0.1% (40mV)
	$\pm 200\text{V}$	0.025% (100mV)
	$\pm 10\text{mA}$	0.1% (20 μA)
	$\pm 100\text{mA}$	0.025% (50 μA)
Response Time	Dynamic Deadband: Relay status will change when proper setpoint/process condition exists for 100mSec or greater Normal Mode: $< 250\text{mSec}$ (analog filtering)	
Setpoint	Effectivity: Setpoints are adjustable (by push-button) over 100% of the selected input span	
Repeatability	$> 200\text{mV}/10\text{mA}$: 0.1% of full scale (constant temperature) $< 200\text{mV}/10\text{mA}$: 0.2% of full scale	
Relay Contacts	2 SPDT (2 form C) Relays 1 relay per setpoint Current rating (general use) 120VAC: 5A 240VAC: 2A 28VDC: 5A	
Material	Gold flash over silver alloy	
Electrical Life	10^5 operations	
Reset Switch	For cycling the relay without cycling power to the unit. (WV108-0001 only)	
Local Range Selection	By DIP switch	
LED Indication	RUN (Green): On when unit is powered Flashes at 2Hz when input under range. Flashes at 8Hz when input over range.	

LED Indication (con'd)	SETPOINT A (Red): On when Setpoint A is tripped. Status for setting Setpoint A Flashes while calibrating the input level SETPOINT B (Red): On when Setpoint B is tripped Status for setting Setpoint B On while calibrating the input level $\pm 100\text{ppm}$ of FS/ $^{\circ}\text{C}$
Stability Common Mode Rejection Isolation	120dB @ DC, $> 90\text{dB}$ @ 60Hz, or better $\geq 1800\text{VDC}$ or peak AC between contacts, input & power
ESD Susceptibility Humidity non-condensing	Capable of meeting IEC 801-2 level 3 (8kV) Operating: 15 to 95% RH (@45 $^{\circ}\text{C}$) Soak: 90% RH for 24hrs (@60 $^{\circ}\text{C}$) Operating: 0 to 60 $^{\circ}\text{C}$ Storage: -25 to +85 $^{\circ}\text{C}$
Temperature	9 to 30VDC 1.2W typical, (3.25W max w/ both relays energized)
Power	
Excitation Voltage Host Module Interface Default Configuration	24VDC @ 20mA IR link Input: Current Range: $\pm 100\text{mA}$ Output: Dual, SPDT Trip: A: Hi, B: Lo Failsafe: No Deadband: A, B: minimum

Physical

Size	DIN rail case – 0.69" wide (17.5mm), refer to Dimensions drawing
Environmental	Operating Temperature: 0 $^{\circ}\text{C}$ to +60 $^{\circ}\text{C}$ (32 to 140 $^{\circ}\text{F}$) Storage Temperature: -25 $^{\circ}\text{C}$ to +85 $^{\circ}\text{C}$ (-13 to 185 $^{\circ}\text{F}$) Operating Relative Humidity (non condensing): 15% to 95%RH at 45 $^{\circ}\text{C}$ Non-operating Relative Humidity: 90%RH at 60 $^{\circ}\text{C}$ for 24 hours
Agency Approvals (EMC & Safety)	CE, EN61326, EN61010-1 UL and CSA Combined mark

MODELS & ACCESSORIES

Ordering Information

Specify:

1. Model: **WV108-0000** or **WV108-0001**
2. Optional Custom Factory Calibration (specify **C620** with desired input and output range.
3. Accessories

Accessories

All WV Series modules will mount on standard TS35 (model MD03) DIN rail. In addition, the following accessories are available:

WVC16 WebView Communications Interface

MD03	TS35 x 7.5 DIN Rail (2 meters)
WV905	24VDC Power Supply (0.5 Amp)
H910	24VDC Power Supply (1 Amp)
H915	24VDC Power Supply (2.3 Amp)
MB03	End Bracket for MD03
C650	Utility software for WVC16

大连爱克新仪器有限公司

www.actionio.com.cn

辽宁省大连市中山区七七街23号海鹰大厦403室

电话: 0411-82650498 : 传真: 0411-82650478

Email: Sales@actionio.com.cn Support@actionio.com.cn

