

WV468

MODEL

- Lower Power Requirements with Smart Power Control
- Greatly Improved Input/Output Accuracy and Stability
- Configurable via DIP Switch or PC Programmable
- Direct Access to Sensor Data when Connected to the Intranet (with optional WVC16)
- Provides Remote Diagnostic Capability (with optional WVC16)
- Versatile Alarm Capabilities Provide Email Notification when Problems Occur (with optional WVC16)
- Lifetime Warranty

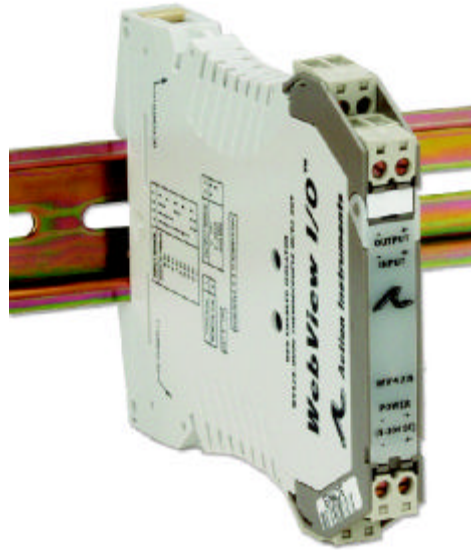

WV Series AC Voltage/Current Input Isolating Signal Conditioner

Traditional Signal Isolator with Not so Traditional Features

DESCRIPTION

The WV Series from Eurotherm Action Instruments is an exciting new line of isolating signal conditioners. This new line provides features never before found in traditional signal conditioners. The WV Series has greater input and output accuracy than most signal conditioners on the market today. In addition, the stability of the unit beats that of most signal conditioners as well. Another feature, unique from other signal conditioners, is Smart Power. Smart Power eliminates wasted power in current output mode for low loop resistances loads. In addition, the WV Series provides the user with the capability to view sensor data directly over your company's intranet with a standard browser. Just imagine, the WV Series will allow you to view configuration, maintenance and process information through a remote browser. Further, the modules are capable of generating scripted e-mail messages, triggered when process variables or maintenance based performance parameters exceed or fall below pre-set levels.

The WV468 has both voltage and current input ranges available. For voltage, eight ranges are DIP switch selectable, 50mV, 150mV, 500mV, 5V, 20V, 50V, 150V & 250VAC. Each of these ranges has at least 95% zero and span adjustment. Current input ranges are 20mA and 100mAAC. Outputs include 0-10V, 0-20mA and 4-20mA. The WV468 also supports reverse output mode.

SMART POWER

The WV Series modules incorporate Smart Power for their output supplies, providing a potential power savings of 500mW per unit. Smart Power adjusts its output voltage and current, depending upon the power output required to drive the current load. A low impedance current loop will now use less power than a high impedance current loop. Previous technology only allowed for a single supply at the highest voltage required to drive the highest impedance load. Low impedance loops only require an output supply voltage of 5VDC. For a 20mA current, this consumes 100mW. In comparison, a high impedance load or older style supply requires 26VDC. This would consume 520mW.

ENHANCED LED DIAGNOSTICS

Other than when executing the push button calibration routine, the LEDs blink under the following conditions:

GREEN: 2Hz when the **input** is **under** range
8Hz when the **input** is **over** range

RED: 2Hz when the **output** is **under** range
8Hz when the **output** is **over** range

An Under range condition exists when the signal is lower than the operational low value minus 6.25% of the operational span. An Over Range condition exists when the signal is higher than the operational high value plus 6.25% of the operational span.

A voltage output short circuit may cause an under range condition (RED blinking at 2Hz rate). A current output open circuit may cause an over range condition (RED blinking at an 8Hz rate).

There could be two or more LEDs blinking at the same time. That means the module has more than one error condition. Only when all error conditions have been removed, will the LEDs be back to normal (Green ON, Red and Yellow Off).

CONFIGURING MODULES

As mentioned above, configuration is accomplished via setting DIP switches and using a push button for calibrating ranges. Additionally, it is possible to remotely modify parameters of each module, such as range, using an Ethernet connection to the WVC16 and a remote PC-based web browser. The browsers supported include Internet Explorer 5 or later and Netscape Navigator 4.7. From the browser, it is possible to configure any of three alarms that would be available from each input (see ALARMS below). The configuration of alarms includes the ability to set alarm limit values for each input and the ability to trigger generation of an e-mail message when an alarm limit condition is invoked. Once the alarm is triggered, the WVC16 will e-mail the specified users (up to 10) if desired. The message can contain the following: Date/Time the trigger occurred, Trigger Name, trigger Type, Trigger value (if applicable), Module Name and WVC16 name.

ALARMS

Each module supports up to three alarms. These alarms could be configured to support the following: high limit, low limit and a timer for routine maintenance.

WEBVIEW COMMUNICATIONS INTERFACE (Optional)

Each WVC16 is capable of communicating with up to 32 I/O modules. The interface contains a web page server and an e-mail server as well as being the interface to the modules. All memory to support the signal conditioner's historical data, storage of the web pages and all e-mail messages is contained in the WVC16.

The WVC16 actually downloads a JAVA applet to the client's computer. The applet provides access to the signal conditioner's data. The information available includes the following:

- Module configuration summary
- Module configuration editing
- Diagnostic/warning status
- Alarm setup & status
- E-mail setup, editing & address book
- Process variable viewing

FACTORY ASSISTANCE

For additional information on installation, operation and calibration, please contact Action's Technical Services Group. Call toll free:

86-411-82650498

DIMENSIONS

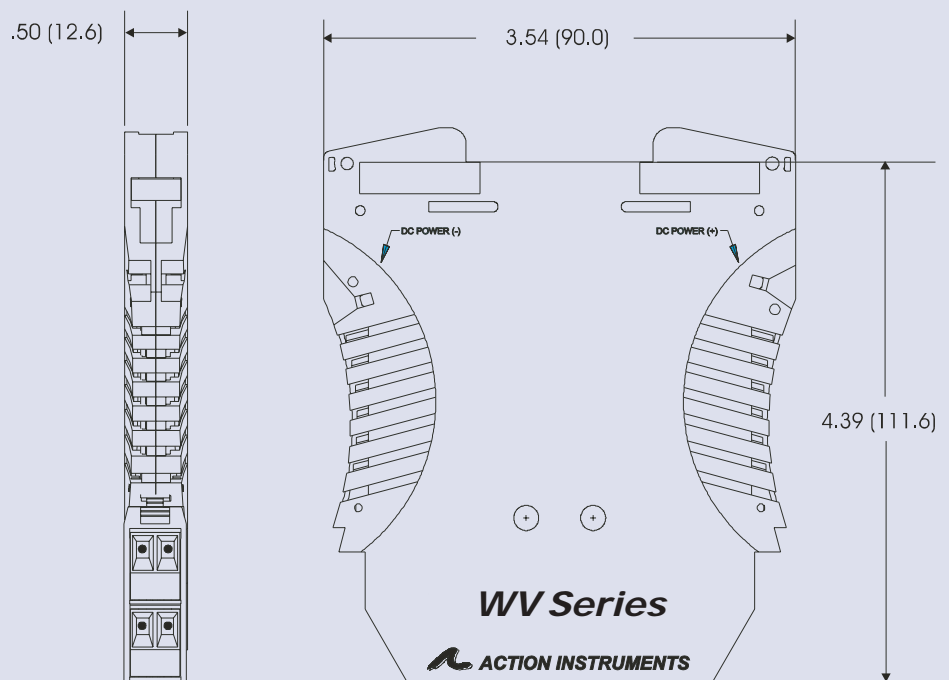

SPECIFICATIONS

Inputs

Voltage Ranges	50mV, 150mV, 500mV, 5V, 20V, 50V, 150V, 250V @ ±0.15% of FS accuracy
	Impedance > 100kΩ
Over-voltage	275VAC
Current Ranges	20mA, 100mA @ ±0.15% of FS accuracy
Impedance	20Ω, or lower if possible
Over-current	200mA, protected by self-resetting fuse
Over-voltage	60V
Frequency Range	40 to 400Hz
Linearity	± 0.1% of span, typical
Input Ranges	Push-button adjustable Effective zero offset: ≥ 95% Effective span turndown: ≥ 95%
Turn-Up/ Turn-Down	80% (90% to ±0.25%)
Common Mode Rejection	60Hz: > 100dB DC: > 120dB
Output Ranges	0-10VDC 0-20mA, 4-20mA
Response Time	100mSec typical
Stability	± 100ppm of span/°C
Output Ripple	0.2% of span, or 5mVrms, whichever is greater

Output Impedance	Voltage Output: < 10Ω (source impedance) Current Output: > 100kΩ
Output Drive	Voltage Output: 10mA, max Current Output: 18V compliance @ 20mA
LED Indication	Green: On when unit is in normal operation Flashes at 2Hz rate when input is under range by 6.25% Flashes at 8Hz rate when input is over range by 6.25% RED: On when calibrating the output level Flashes at 2Hz rate when the output is under range by 6.25% Flashes at 8Hz rate when the output is over range by 6.25% YELLOW: On while calibrating the input level
Temperature Range	Operating: 0° to 60°C (32 to 140°F) Storage: -20° to 85°C (-4 to 185°F)
Power	9 to 30VDC 1W typical, 2W maximum
Isolation	Input to Output to Power: 1800VDC
Host Module Interface	IRLink
Default Configuration	Input Range: 0-500mVAC Output Range: 4 to 20mA

Specifications are subject to change.

MODELS & ACCESSORIES

Ordering Information

Specify:

- Model: **WV468-2000**
- Optional Custom Factory Calibration (specify **C620** with de sired input and output range.
- Accessories

Accessories

All WV Series modules will mount on standard TS35 (model MD03) DIN rail. In addition, the following accessories are available:

WVC16	WebView Communications Interface
MD03	TS35 x 7.5 DIN Rail (2 meters)
WV905	24VDC Power Supply (0.5 Amp)
H910	24VDC Power Supply (1 Amp)
H915	24VDC Power Supply (2.3 Amp)
MB03	End Bracket for MD03

Terminal Connections

Terminal	Function
11	DC Power (+)
12	DC Power (-)
21	DC Power (+)
22	DC Power (-)
41	AC Input (hot)
42	AC Input (neu)
51	Output (+)
52	Output Common

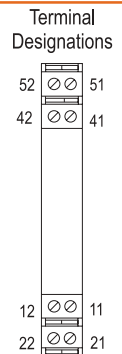

大连爱克新仪器有限公司

www.actionio.com.cn

辽宁省大连市中山区七七街23号海鹰大厦403室

电话: 0411-82650498 : 传真: 0411-82650478

Email: Sales@actionio.com.cn Support@actionio.com.cn

